

FLUSH MOUNTED

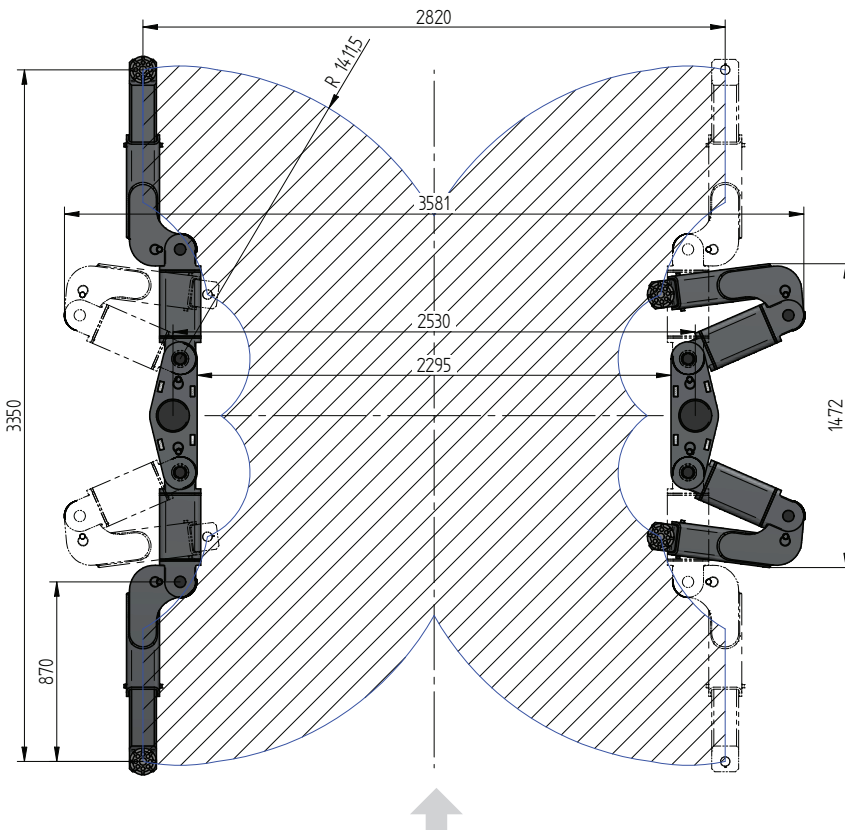
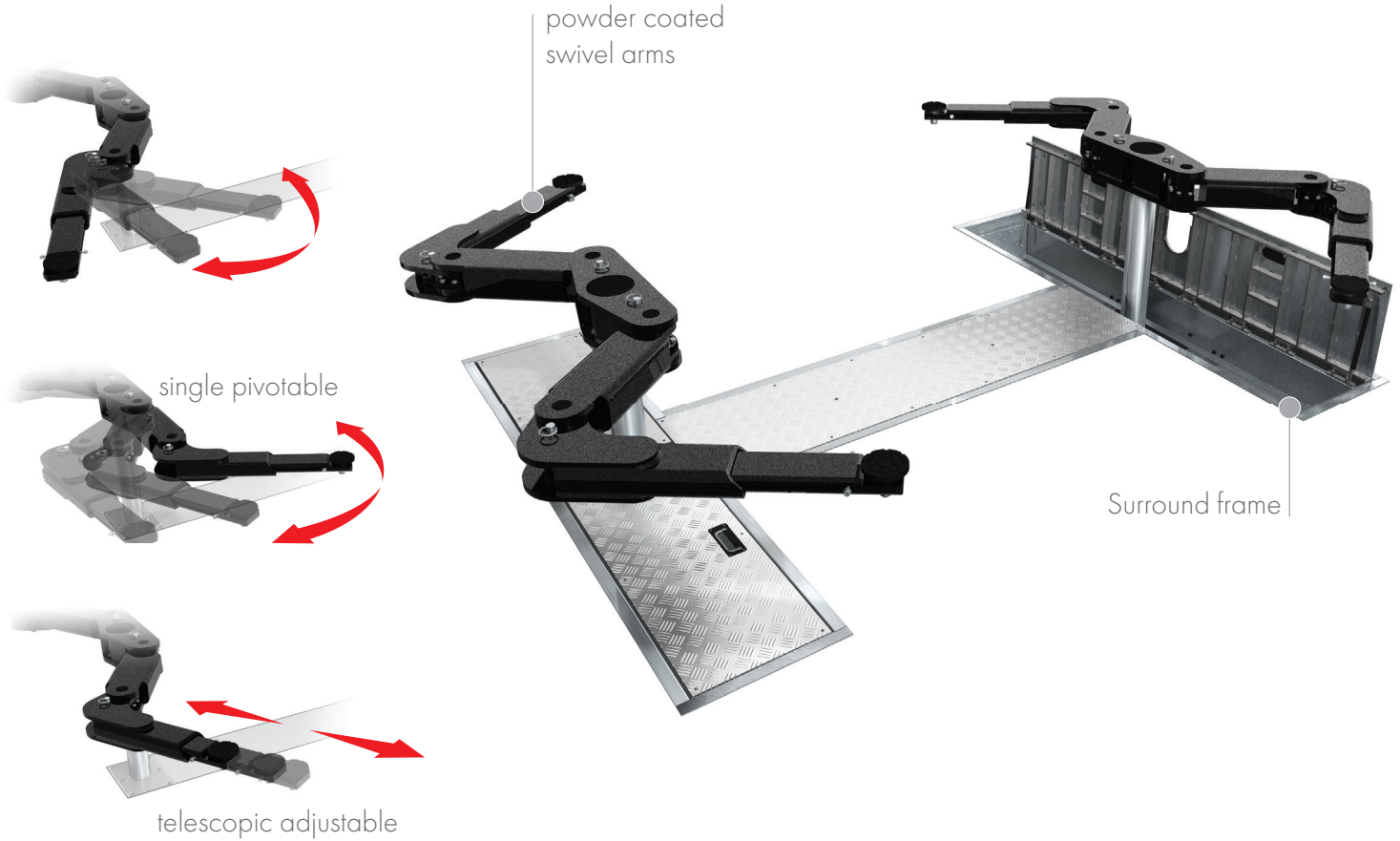

TECHNICAL DATA

Capacity	4000 kg
Effective raise height	2033 mm
Drive over height	95 mm
Piston diameter	123 mm
Piston distance	2530 mm
Installation depth	2408 mm
Motor output	3,0 kW
Power connector	400 V/16 A
Cable length to control	11 m
Lifting time	≈ 35 sec.
Lowering time	≈ 35 sec.

Support Multiarm 2.40	112119
Installation cassette STEEL 2530 mm	2330XX
Installation cassette STEEL 2530 mm galvanized	2331XX
Lifting unit oil 4,0 t 2530 mm - K pre-assembled in installation cassette	111618
Lifting unit oil 4,0 t 2530 mm - H packed in wooden box	111619
Surround frame Multiarm 2530	113295

ACCESSORIES

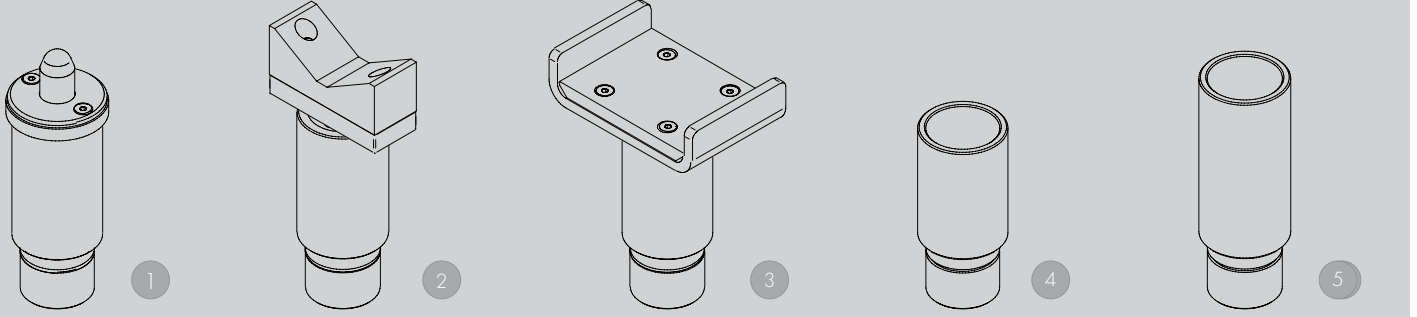

1 | Stacking adapter NCV3
d 50 x d 70 / 115-215 mm
112100 (1 set / 2 pcs.)

2 | Stacking adapter V-prism
d 50 / 87-130 mm
109683 (1 set / 2 pcs.)

3 | Stacking adapter U-form
d 50
1103976 (1 set / 4 pcs.)

4 | Stacking adapter extension
89 mm
109679 (1 set / 4 pcs.)

5 | Stacking adapter extension
127 mm
109680 (1 set / 4 pcs.)

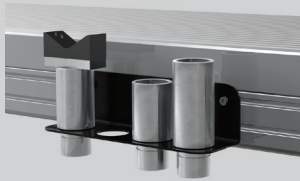

Bracket for stacking-
adapter extension
111578

Herrmann AG
Bahnhofstrasse 32
D-93483 Pöding

+49 (0)9461/91388 50
sales@herrmann-lifts.com
www.herrmann-lifts.com